

Concert Element 90

Hi-fi Floorstanding Speakers

Concert Element's design conviction – that the purest expression of what a speaker needs to do is usually the best one – reaches its fullest form in Concert Element 90.

The circular driver module scales to floorstanding proportions while the shallow cabinet maintains the minimal footprint of the family; internal bracing and a dual-chamber construction manage the acoustic demands a larger enclosure places on the midrange.

A 3-way architecture with a 250 mm woofer delivers full-range extension from 30 Hz without a subwoofer. The complete passive system, for the room it is made for.

Key Features

25 mm soft dome tweeter with Waveguide – Balanced precision and smoothness for increased airiness and detail.

Bespoke drivers designed in Denmark – Nettle fibre cones on 165 mm midrange and 250 mm woofer.

Dual-chamber cabinet – Ported woofer, sealed midrange. No bass contamination.

Down-firing port tube – Flexible placement, no compromise in audio quality.



Dimensions

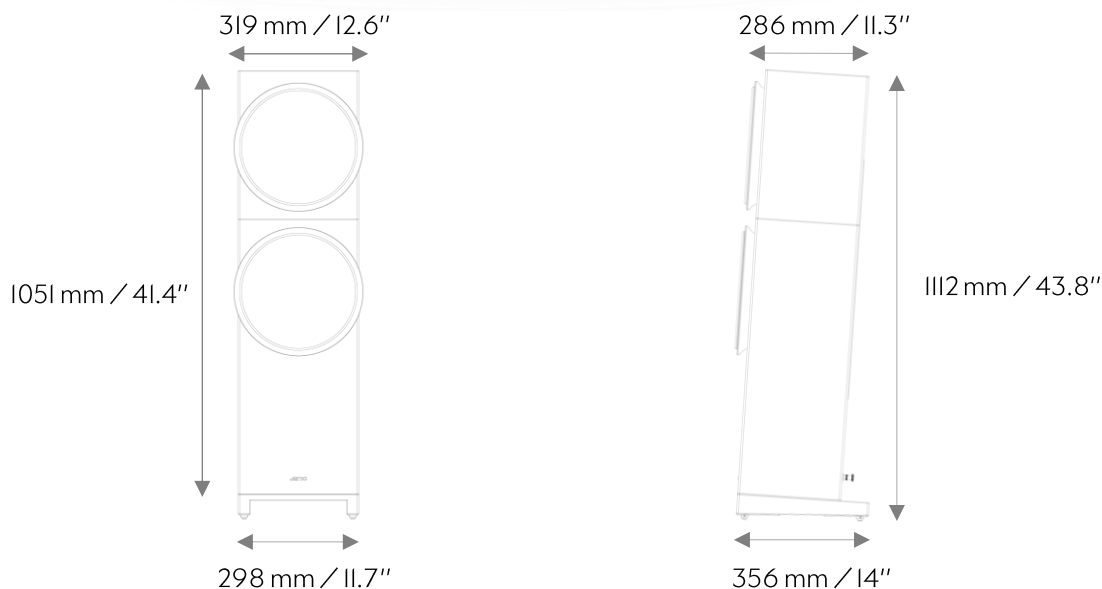

Technical Specifications

Acoustical Features	Type	Hi-fi floorstanding passive speakers 3-way bass-reflex
	Speaker Drivers Configuration & Technologies	<ul style="list-style-type: none"> • LF : 1 x 250 mm (10") woofer Scandinavian nettle fibre cone 4 layers voice coil • MF : 1 x 165 mm (6.5") medium Scandinavian nettle fibre cone • HF : 1 x 25 mm (1") tweeter Soft positive dome
	Bandwidth (+/-3dB)	35 Hz – 22 kHz
	Low-frequency Cut-off (-6dB)	30 Hz
	Sensitivity (2.83V @ 1m)	87 dB
	Recommended Amplifier Power	60 W – 250 W
	Impedance	4 Ω
	Inputs	Bi-wiring terminal
Product Main Information	Product Dimensions (Including Feet) H x W x D (mm) H x W x D (inches)	1112 x 319 x 356 mm 43.8" x 12.6" x 14"
	Net Product Weight (Unit)	33.2 kg / 73.2 lbs
	Included Accessories	Magnetic grilles (2 sets); dark grey and light grey Adjustable rubber feet Terminal jumpers
	Available Colours	<ul style="list-style-type: none"> ● Onyx ● Northern Frost



Onyx



Northern Frost